

PLAFON / PLAFOND / PLAFOND

NERO 2

czarny, złoty / black, gold / schwarz, golden



💡 GU10, 2 x 40 W, 2 x 12 W LED *

⚡ ~ 220-230 V, 50-60 Hz

📏 30 x 5 x 18 cm 📏 6/8,5 cm

🏠 stal / steel / Stahl

🌐 czarny/złoty / black/golden / schwarz/Gold

📦 18 x 13 x 32 cm

📦 netto: 0,94 kg, brutto: 1,05 kg
/ net: 0,94 kg, gross: 1,05 kg
/ netz: 0,94 kg, brutto: 1,05 kg

🌧️ IP20



Podzespoły zastosowane w oprawach:

- oprawka GU10, 2 A, 250 V
- przewód przyłączeniowy 0,75 mm²
- złączki zaciskowe

/ Components used in luminaries:

- holder GU10, 2 A, 250 V
- connection cable 0,75 mm²
- compression fittings

/ Bauelemente der Fassungen:

- fassung GU10, 2 A, 250 V
- elektrische Leitung 0,75 mm²
- Klemmen



CE

SL.1070

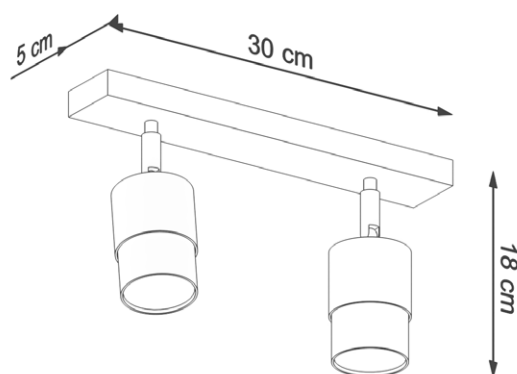

5 903282 724105

* Źródło światła nie jest w komplecie / Light bulb not included / Leuchtmittel nicht inkl.



Made in EU