

KINKIET CERAMICZNY / WALL LAMP CERAMIC / WANDLEUCHTE KERAMIK

# VIXEN



💡 G9, 1 x 40 W, 1 x 12 W LED \*

⚠️ ~ 220-230 V, 50-60 Hz

📏 31,5 x 9,5 x 14 cm

🏠 ceramika, szkło / ceramic, glass / Keramik, Glas

🌈 biały / white / weiß

📦 40 x 20 x 16 cm

📦 netto: 1,25 kg, brutto: 1,4 kg  
/ net: 1,25 kg, gross: 1,4 kg  
/ netz: 1,25 kg, brutto: 1,4 kg

🌧️ IP20



SL.0834

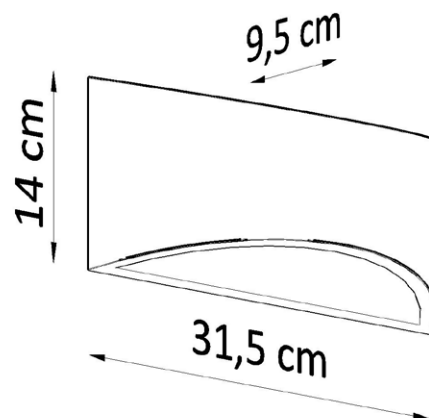

Podzespoły zastosowane w oprawach:

- oprawka G9, 2 A, 250 V

/ Components used in luminaries:

- holder G9, 2 A, 250 V

/ Bauelemente der Fassungen:

- fassung G9, 2 A, 250 V



\* Źródło światła nie jest w komplecie / Light bulb not included / Leuchtmittel nicht inkl.

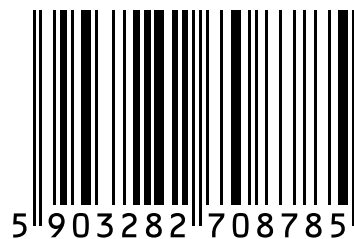

Made in EU