

PLAFON / PLAFOND / PLAFOND

# QUAD 1

antracyt / anthracite / anthrazit



💡 GU10, 1 x 40 W, 1 x 12 W LED \*

⚡ ~ 220-230 V, 50-60 Hz

📏 10 x 10 x 10 cm

🏠 aluminium / aluminium / Aluminium

🌿 antracyt / anthracite / anthrazit

📦 13 x 13 x 13 cm

📦 netto: 0,45 kg, brutto: 0,60 kg  
/ net: 0,45 kg, gross: 0,60 kg  
/ netz: 0,45 kg, brutto: 0,60 kg

🌧️ IP20



Podzespoły zastosowane w oprawach:

- oprawka G9, 2 A, 250 V
- przewód przyłączeniowy 0,75 mm<sup>2</sup>
- złączki zaciskowe

/ Components used in luminaries:

- holder G9, 2 A, 250 V
- connection cable 0,75 mm<sup>2</sup>
- compression fittings

/ Bauelemente der Fassungen:

- fassung G9, 2 A, 250 V
- elektrische Leitung 0,75 mm<sup>2</sup>
- Klemmen



SL.0567

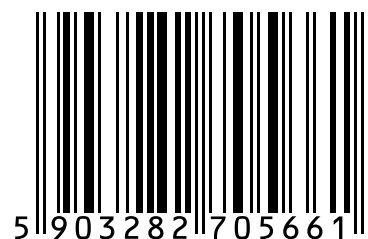
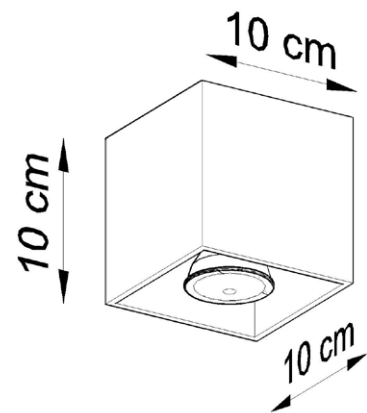

\* Źródło światła nie jest w komplecie / Light bulb not included / Leuchtmittel nicht inkl.



Made in EU