

PLAFON / PLAFOND / PLAFOND

FENIKS 2

naturalne drewno / natural wood / Holz



💡 E27, 2 x 60 W, 2 x 15 W LED *

⚡ ~ 220-230 V, 50-60 Hz

📏 43 x 43 x 12 cm

🪵 drewno, szkło / wood, glass / Holz, Glas

🌿 naturalne drewno / natural wood / Natural Holz

📦 50 x 20 x 20 cm

📦 netto: 2,3 kg, brutto: 2,45 kg
/ net: 2,3 kg, gross: 2,45 kg
/ netz: 2,3 kg, brutto: 2,45 kg

☔ IP20



SL.0076

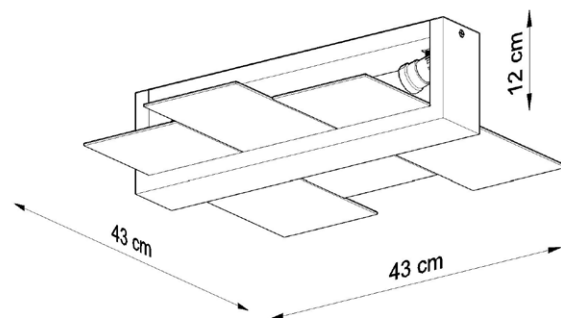

Podzespoły zastosowane w oprawach:

- oprawka E27, 4 A, 250 V
- przewód przyłączeniowy 0,75 mm²
- złączki zaciskowe

/ Components used in luminaries:

- holder E27, 4 A, 250 V
- connection cable 0,75 mm²
- compression fittings

/ Bauelemente der Fassungen:

- fassung E27, 4 A, 250 V
- elektrische Leitung 0,75 mm²
- Klemmen



* Źródło światła nie jest w komplecie / Light bulb not included / Leuchtmittel nicht inkl.



Made in EU