

PLAFON / PLAFOND / PLAFOND

QUAD 2

czarny / black / schwarz



💡 GU10, 2 x 40 W, 2 x 12 W LED *

⚡ ~ 220-230 V, 50-60 Hz

📏 26 x 11 x 12 cm

🏠 aluminium / aluminium / Aluminium

🎨 czarny / black / schwarz

📦 14 x 14 x 31 cm

📦 netto: 1,5 kg, brutto: 1,65 kg
/ net: 1,5 kg, gross: 1,65 kg
/ netz: 1,5 kg, brutto: 1,65 kg

Podzespoły zastosowane w oprawkach:

- oprawka GU10, 2 A, 250 V
- przewód przyłączeniowy 0,75 mm²
- złączki zaciskowe

/ Components used in luminaries:

- holder GU10, 2 A, 250 V
- connection cable 0,75 mm²
- compression fittings

/ Bauelemente der Fassungen:

- fassung GU10, 2 A, 250 V
- elektrische Leitung 0,75 mm²
- Klemmen

💧 IP20



SL.0063

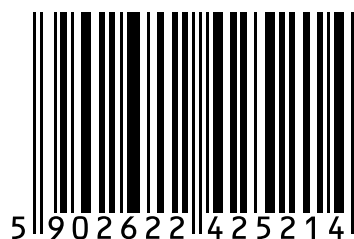
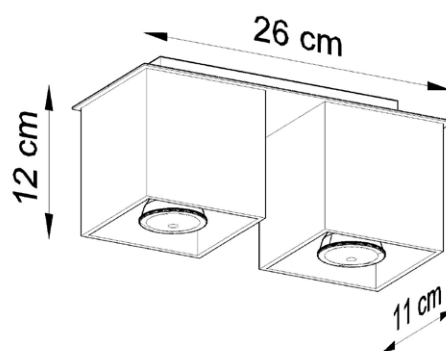

* Źródło światła nie jest w komplecie / Light bulb not included / Leuchtmittel nicht inkl.



Made in EU