

KINKIET CERAMICZNY / WALL LAMP CERAMIC / WANDLEUCHTE KERAMIK

GLOBE



-  E27, 1 x 60 W, 1 x 15 W LED *
-  ~ 220-230 V, 50-60 Hz
-  18 x 11 x 14,5 cm
-  ceramika / ceramic / Keramik
-  biały / white / weiß
-  25 x 25 x 20 cm
-  netto: 1,05 kg, brutto: 1,20 kg
/ net: 1,05 kg, gross: 1,20 kg
/ netz: 1,05 kg, brutto: 1,20 kg

 IP20
 

Podzespoły zastosowane w oprawkach:

- oprawka E27, 4 A, 250 V

/ Components used in luminaries:

- holder E27, 4 A, 250 V

/ Bauelemente der Fassungen:

- fassung E27, 4 A, 250 V



* Źródło światła nie jest w komplecie / Light bulb not included / Leuchtmittel nicht inkl.

SL.0032

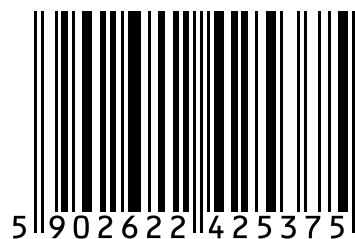
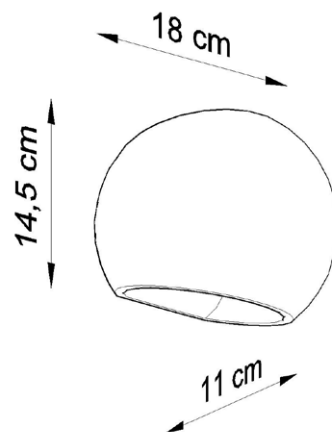

Made in EU